



Manufacturing ▪ Marketing ▪ Sourcing



## Anti Vibration Mounts

Why tolerate vibration ? Control it ...

[www.antivibrations.com](http://www.antivibrations.com) | [www.amtplindia.com](http://www.amtplindia.com)

## AMT Machine Mount, Series MM

AMT MM series machine mounts are well suited for mounting workshop machinery without being anchored to the ground especially for machines with high vertical and horizontal forces. These ready to install mounts allow immediate commissioning, eliminating the need for foundations or grouting. The height adjustment feature allows precise leveling of machinery. These mounts will insulate high frequency vibrations and sound and prevent wandering of machinery due to the large contact area. Also the anti vibration material used has high resistance to acids, alkalis and oils.

### Application

- General purpose machine mounts
- Machine tool industry
- Plastic industry
- Sheet metal industry
- Food industry
- Beverage industry
- Pharmaceutical industry

### Advantages

- Quick and easy installation. No need for anchoring.
- Isolate strong vibrations that are dangerous, both for the operator and machinery. Achieve a higher work peace quality.
- Reduce maintenance and repair costs as pre-mature wear of machinery is avoided.
- Good resistance to machine coolants and oils.



Description	UOM	Product Code			
		AMT-MM1	AMT-MM2	AMT-MM3	AMT-MM4
Diameter (D)	mm	80	120	160	200
Height (H)	mm	45	45	56	68
Stud Size (d)	mm	M12x1.5x110	M16x1.5x110	M20x1.5x160	M20x1.5x160
Adjustment (A)	mm	12	15	21	21
Min / Max Load per mount	Kg	50 – 500	200 – 1100	800 – 2100	1500 – 4000

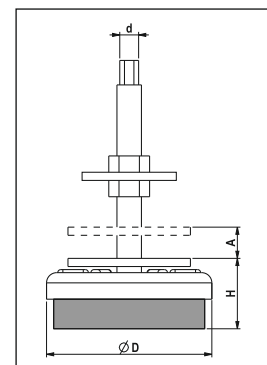

## AMT Machine Mounts, Series MH

AMT MH series machine mounts are ideal for machines exerting significant vertical and horizontal forces, where a secure, high-precision connection with the machine is required. The unique design absorbs impulses and shock in high-speed machinery, where vibration damping is critical. Levelling accuracy of 1/100mm is achieved over the entire adjustment range. An integral locking device prevents the mount from coming apart during installation or relocation of the machine. It maintains excellent horizontal dynamic stability and provide vibration dampening during machine operation.

### Application

- Injection and blow molding machines
- Machine tool industry
- Extrusion machines
- Granulators
- Conveyors

### Advantages

- Excellent horizontal dynamic stability.
- Minimal lateral de
- Reduced overall height.
- Precise leveling. Fine height adjustment under full load
- Effective machinery isolation allows increased production output.
- Ease of machine mobility.



Description	UOM	Product Code		
		AMT-MH1	AMT-MH2	AMT-MH3
Diameter (D)	mm	130	170	200
Height (H)	mm	62	62	62
Stud Size (d)	mm	M16x1.5x150	M20x1.5x150	M24x1.5x150
Adjustment (A)	mm	19	22	22
Min / Max Load per mount	Kg	50 – 500	200 – 1100	800 – 2100

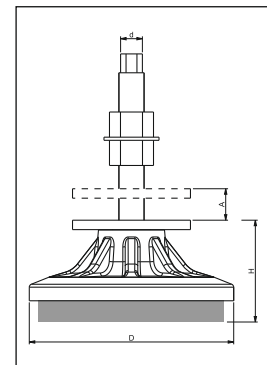

## AMT Machine Mounts, Series ML

The AMT ML series leveling mounts are well equipped for many applications. These economical mounts provide fast, easy, and precise leveling.

The unique design of connecting leveler and levelling stud is can automatically compensate ground unevenness of up to 4°. The anchor-free setup and the simple levelling with great levelling range guarantee maximum of your machinery

### Application

- Drilling, Milling and Lathe machines
- Production conveyors
- Packaging
- Automated assembly equipment
- Material handling equipment's
- Electrical equipment and displays
- Equipment benches
- Wood working machines

### Advantages

- Fast, easy and economical levelling can be achieved.
- Good for compensating
- High durability.

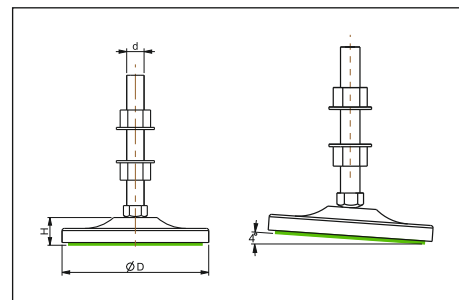

Description	UOM	Product Code		
		AMT-ML1	AMT-ML2	AMT-ML3
Diameter (D)	mm	85	135	175
Height ( H)	mm	19.5	25	26
Stud Size (d)	mm	M12x1.75x100 LG	M16x1.5x120 LG	M20x1.5x150 LG
Max Load per mount	Kg	650	1650	3000

## AMT Machine Fixator, Series MF

AMT MF series machine is a one stop solution for precise yet cost effective installation of heavy machinery and equipment. They are available in two basic designs: **bolt-through** and **bolt-on**. The "bolt-through" design has a clearance hole for an anchor bolt to securely anchor machines to the floor or foundation. The "bolt-on" design comes with fasteners and is designed for free-standing installations.

MF series machine is based on double wedge principle. Both wedges move towards or away from the loading center symmetrically. Equalizing these forces around the center results in an absolute rigid and stable anchoring system. As there is equal load distribution through two lifting wedges, the force required to raise or lower a machine is reduced considerably, resulting in effortless and precision leveling.

### Application

- Heavy machine tools for processing crankshafts and camshafts or rollers
- Boring machines, gear testing machines, horizontal and critical machining centers
- Surface grinding and laser cutting machines
- Die-casting and plastic injection molding machines
- Punching and press machines
- Turbine and compressors
- Printing machines

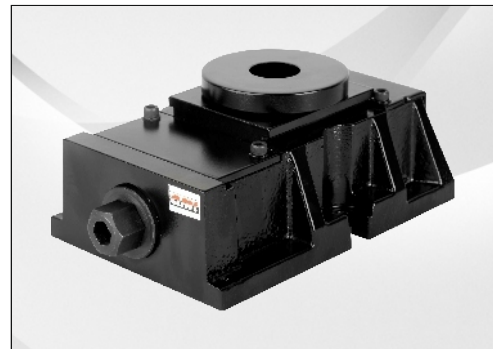

### Advantages

- Precise and accurate machine positioning and leveling.
- Considerable reduction in machine maintenance cost.
- Machine accuracy maintained for longer duration.
- Reduced installation time thanks to effortless and precise leveling.
- No horizontal machine movement.
- No special foundation required.
- Sufficient adjustment height.

Description	UOM	Product Code		
		AMT-MF1	AMT-MF2	AMT-MF3
Max load per mount	Kg	2000	4000	5500
Permissible maximum load	Kg	12000	24000	36000
<b>Dimensional Data</b>				
Length x Width x Height (LxBxH)	mm	180x120x75	220x145x95	270x180x110
Height adjustment (h)	mm	5	6	7
Bolt through size ( $\phi f$ )	mm	24	28	37
Bolt on size (M)	mm	M20	M24	M30
Adjustment screw hex head (SW)	mm	22	27	27
Resting Diameter (D)	mm	75	92	113
c	mm	32	34	43
l	mm	95	122	145
e1	mm	14	18	22
e2	mm	26	32	39

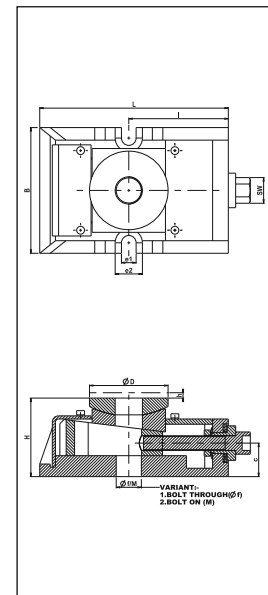

## AMT Neoprene Mounts, Series N

AMT Series N neoprene mounts allow excellent attenuation of medium to high frequency vibration and noise generated from a wide range of motor driven machines particularly axial and centrifugal fans.

Series N mounts are used to isolate a wide range of equipment and can be bolted to equipment mounting holes with the supplied cap screw and washer. However it is not necessary to bolt these mountings to the on most installations. They can be used under bases that have no bolt holes in much the same manner as rubber pads. The mounting may be inverted so that the rectangular rubber covered steel base plate provides support over a large area.

### Application

- Test rigs and special purpose machines
- Rotary and multi cylinder compressors
- Refrigeration plant and chillers
- Paper and printing machinery
- Axial and centrifugal fans
- Pumps and motors
- Air handling units
- Gen-Sets
- Mills



### Advantages

- Economical, Quick and easy to install.
- Reduce machine maintenance and cost.
- Prevents noise and high frequency vibrations.
- Neoprene covering prevents corrosion of steel parts.
- Suitable as shock isolators for both active & passive vibrations.
- Bottom friction surface makes bolting not necessary in most installations.

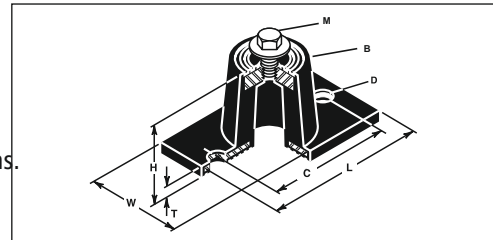

Description	UOM	Product Code						
		AMT N-A30	AMT N-A50	AMT N-A60	AMT N-A70	AMT N-B70	AMT N-C50	AMT N-C70
Min / Max Load per mount	Kg	10-30	20-70	90-350	120-550	200-700	200-1000	500-2200
Max Static De	mm		7		13	13		8
<b>Dimensional Data</b>								
L x W x H	mm	80x45x40		140x85x70		165x100x75		190x130x65
C	mm	60		105		127		155
T	mm	6		7		7		7
D	mm	10		14		14		14
B	mm	40		65		76		110
M	mm	M8		M12		M12		M16

## AMT Cushy Foot Mounts, Series C

AMT C series cushy foot mounts employ the well proven inclined rubber element design to achieve much higher de compared to simple rubber in compression devices and therefore superior isolation of low frequency vibration.

These mounts consists of two rubber sandwich pieces housed in specially designed robust iron casting. The mountings are protected against oil, physical & mechanical damages. AMT Cushy Foot Mounts give insulation against transverse, vertical and longitudinal stiffness, vibration & reduces transmission of vibrations, structure borne noise & shock from a wide range of rotating and reciprocating machineries. These mounts have very low natural frequencies and possess good lateral stability.

### Application

- Diesel Generating Sets
- Engine Test Beds
- Lift Motor Gear
- Chillers and Cooling Towers
- Large Fans and AHU's
- Pumps and Compressors
- Vibrating Screens and Hoppers
- Paper and Printing Machines
- Food Processing Machines
- Blowers

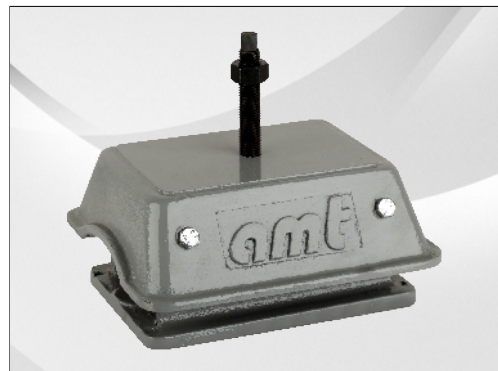

### Advantages

- Rubber to metal bonded rectangular elements inclined to achieve maximum load and de using a combination of compression and shear loading.
- High strength cast iron castings.
- Rubber sandwich elements are effectively protected by the top casting and its extended skirt.
- Two different horizontal stiffness axis enable optimum system characteristics & vibration isolation to be achieved using careful orientation of the mounting.

Product Code	Max Load / Mount (kg)	Dimensions (mm)					
		A	B	C	D	E	H
AMT-C-A1	100						
AMT-C-A2	160	75	80	128	110	12.5	M12
AMT-C-A3	250						
AMT-C-B1	400						
AMT-C-B2	800						
AMT-C-B3	1200	110	145	205	208	18	M16
AMT-C-B4	1600						

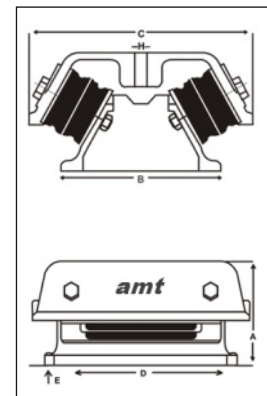

## AMT Machine Mount, Series SMM

AMT SMM series machine mounts are well suited for mounting workshop machinery without being anchored to the ground especially for machines with high vertical and horizontal forces. These ready to install mounts allow immediate commissioning, eliminating the need for foundations or grouting. The height adjustment feature allows precise leveling of machinery. These mounts will insulate high frequency vibrations and sound and prevent wandering of machinery due to the large contact area. Also the anti vibration material used has high resistance to acids, alkalis and oils.

### Application

- General purpose machine mounts
- Machine tool industry
- Plastic industry
- Sheet metal industry
- Food industry
- Beverage industry
- Pharmaceutical industry

### Advantages

- Quick and easy installation. No need for anchoring.
- Isolate strong vibrations that are dangerous, both for the operator and machinery. Achieve a higher work peace quality.
- Reduce maintenance and repair costs as pre-mature wear of machinery is avoided.
- Good resistance to machine coolants and oils.



Description	UOM	Product Code		
		AMT-SMM 1	AMT-SMM2	AMT-SMM3
Diameter (D)	mm	80	120	160
Height (H)	mm	72	77	92
Bolt on Stud Size	mm	M12 x 100	M12 x 100	M16 x 100
Range of Height Adjustment	mm	12 mm	13 mm	16 mm
Maximum safe Working Height of Mount	mm	84	92	102
Min / Max Load per mount	kg	50-500	200-1100	800-2100

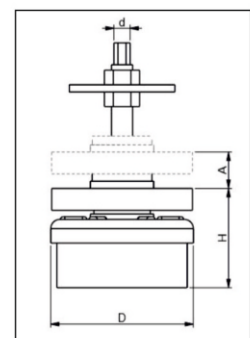





Manufacturing ▪ Marketing ▪ Sourcing

Manufactured by

**MACHINE HOUSE (INDIA) PVT. LTD.**  
amt Group Company

WORKS : W-82(A), MIDC, Ambad, Nashik - 422 010 INDIA.

CORPORATE OFFICE : D-1/18, M.I.D.C. Ambad, Nashik - 422 010 INDIA.

Ph. : +91-253-2307662 | Email : bilzindia@gmail.com, info@antivibrations.com

[www.antivibrations.com](http://www.antivibrations.com) | [www.amtplindia.com](http://www.amtplindia.com)